

STANNAH LIFTS LTD

TECHNICAL BULLETIN**INFORMATION ONLY****For the Attention of :** Installers, Trade Customers, Testers, Training Dept**Date :** 25-11-2009**Product :** MRLi Hydraulic Passenger Lifts**Subject :** Running the platform prior to fitting the pawl device**Pages :** 1**Originator :** Stannah Lifts Ltd, Anton Mill, Andover, Hants SP10 2NX 01264 339090**Detail**

All MRLi's manufactured after 11th October 2009 have been supplied with a pawl device. Since the pawl device cannot be installed in its fully operational state until the car top box and trailing cables are in place, it is necessary to operate the platform with part of the pawl device control circuit temporarily bypassed.

To operate the platform prior to final fitting of the pawl device, the PDR relay should be temporarily bypassed with two link wires as per the diagram below:

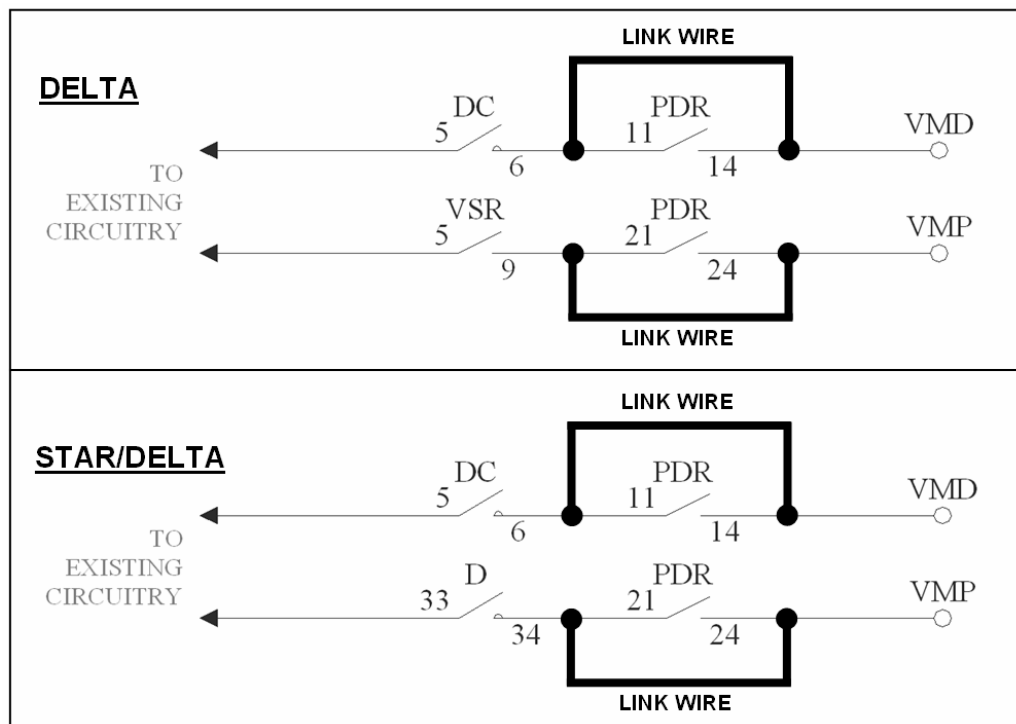

Upon final installation and connection of the pawl device, the temporary link wires must be removed.

Until the pawl device is fully operational, the auxiliary check valve ("Blain valve") and pit prop are provided as means of protection.